

Communicative damper actuator for adjusting dampers in technical building installations

- Air damper size up to approx. 2 m²
- Nominal torque 10 Nm
- Nominal voltage AC/DC 24 V
- Control Modulating
- Conversion of sensor signals
- Communication via Modbus RTU (RS-485)

Technical data

Electrical data	Nominal voltage	AC/DC 24 V
	Nominal voltage frequency	50/60 Hz
	Nominal voltage range	AC 19.2...28.8 V / DC 21.6...28.8 V
	Power consumption in operation	3.5 W
	Power consumption in rest position	1.4 W
	Power consumption for wire sizing	6 VA
	Connection supply / control	Cable 1 m, 6 x 0.75 mm ²
Data bus communication	Protocol	Modbus RTU (RS-485), not galvanically isolated
	Number of nodes	Max. 32 (without repeater)
	Transmission formats	1-8-N-2, 1-8-N-1, 1-8-E-1, 1-8-O-1 Default: 1-8-N-2 (start bits, data bits, parity, stop bits)
	Baud rate	9600, 19,200, 38,400, 76,800, 115,200 Bd Default: 38,400 Bd
	Terminating resistor	120 Ohm, can be switched
	Parameterisation	with Service Tool ZTH EU Pushbutton-operated fast addressing 1 ... 16 possible
	Functional data	Torque motor
Torque variable		25%, 50%, 75% reduced
Position accuracy		±5%
Direction of motion motor		Selectable with switch 0 / 1
Direction of motion note		Y = 0 V: At switch position 0 (ccw rotation) / 1 (cw rotation)
Direction of motion variable		Electronically reversible
Manual override		Gear disengagement with push-button, can be locked
Angle of rotation		Max. 95°
Angle of rotation note		can be limited on both sides with adjustable mechanical end stops
Running time motor		150 s / 90°
Motor running time variable		43...173 s
Adaption setting range		manual
Adaption setting range variable		No action Adaption when switched on Adaption after pushing the gear disengagement button
Override control, controllable via Modbus		MAX (maximum position) = 100% MIN (minimum position) = 0% ZS (intermediate position) = 50%
Override control variable		MAX = (MIN + 32%)...100% MIN = 0%...(MAX - 32%) ZS = MIN...MAX
Sound power level motor		35 dB(A)
Spindle driver		Universal spindle clamp 8...26.7 mm
Position indication	Mechanically, pluggable	
Safety	Protection class IEC/EN	III Safety extra-low voltage
	Protection class UL	UL Class 2 Supply
	Degree of protection IEC/EN	IP54

Technical data

Safety	Degree of protection NEMA/UL	NEMA 2, UL Enclosure Type 2
	EMC	CE according to 2004/108/EC
	Certification IEC/EN	IEC/EN 60730-1 and IEC/EN 60730-2-14
	Certification UL	cULus according to UL 60730-1A, UL 60730-2-14 and CAN/CSA E60730-1:02
	Mode of operation	Type 1
	Rated impulse voltage supply / control	0.8 kV
	Control pollution degree	3
	Ambient temperature	-30...50° C
	Non-operating temperature	-40...80° C
	Ambient humidity	95% r.h., non-condensing
Maintenance	Maintenance-free	
Weight	Weight	0.92 kg

Safety notes



- The device must not be used outside the specified field of application, especially not in aircraft or in any other airborne means of transport.
- Outdoor application: only possible in case that no (sea)water, snow, ice, insolation or aggressive gases interfere directly with the actuator and that is ensured that the ambient conditions remain at any time within the thresholds according to the data sheet.
- Only authorised specialists may carry out installation. All applicable legal or institutional installation regulations must be complied during installation.
- The device may only be opened at the manufacturer's site. It does not contain any parts that can be replaced or repaired by the user.
- Cables must not be removed from the device.
- To calculate the torque required, the specifications supplied by the damper manufacturers concerning the cross-section, the design, the installation site and the ventilation conditions must be observed.
- The device contains electrical and electronic components and must not be disposed of as household refuse. All locally valid regulations and requirements must be observed.

Product features

Mode of operation	The actuator is fitted with an integrated interface for Modbus RTU, it receives the digital positioning signal from the Modbus-Master and returns the current status.
Converter for sensors	Connection option for a sensor (passive or active sensor or switching contact). In this way, the analogue sensor signal can be easily digitised and transferred to Modbus.
Parameterisable actuators	The factory settings cover the most common applications. Single parameters can be modified with the Belimo Service Tools MFT-P or ZTH EU. The Modbus communication parameters (address, baud rate etc.) are set with the ZTH EU. Pressing push-button "Service" on the actuator while connecting the supply voltage resets the communication parameters to the factory setting. Quick addressing: The Modbus address can alternatively be set using push-buttons on the actuator from 1 to 16. The value selected is added to the «Basic address» parameter and results in the effective Modbus address. For example, with a basic address of 140, Modbus addresses between 141 and 156 can be parameterised using quick addressing.
Simple direct mounting	Simple direct mounting on the damper spindle with an universal spindle clamp, supplied with an anti-rotation device to prevent the actuator from rotating.
Manual override	Manual override with push-button possible (the gear is disengaged for as long as the button is pressed or remains locked).
High functional reliability	The actuator is overload protected, requires no limit switches and automatically stops when the end stop is reached.
Adjustable angle of rotation	Adjustable angle of rotation with mechanical end stops.

Product features

Home position The first time the supply voltage is switched on, i.e. at the time of commissioning, the actuator carries out a synchronisation. The synchronisation is in the home position (0%).
The actuator then moves into the position defined by the positioning signal.

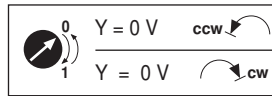

Adaption and synchronisation An adaption can be triggered manually by pressing the “Adaption” button or with the PC-Tool. Both mechanical end stops are detected during the adaption (entire setting range).
Automatic synchronisation after pressing the gearbox disengagement button is configured. The synchronisation is in the home position (0%).
The actuator then moves into the position defined by the positioning signal.
A range of settings can be adapted using the PC-Tool (see MFT-P documentation)

Accessories

	Description	Type
Electrical accessories	Auxiliary switch, add-on, 1 x SPDT	S1A
	Auxiliary switch, add-on, 2 x SPDT	S2A
	Auxiliary switch, add-on, 2 x SPDT, grey	S2A GR
	Feedback potentiometer 140 Ohm, add-on	P140A
	Feedback potentiometer 140 Ohm, add-on, grey	P140A GR
	Feedback potentiometer 200 Ohm, add-on	P200A
	Feedback potentiometer 500 Ohm, add-on	P500A
	Feedback potentiometer 500 Ohm, add-on, grey	P500A GR
	Feedback potentiometer 1 kOhm, add-on	P1000A
	Feedback potentiometer 2.8 kOhm, add-on	P2800A
	Feedback potentiometer 2.8 kOhm, add-on, grey	P2800A GR
	Feedback potentiometer 1 kOhm, add-on, grey	P1000A GR
	Feedback potentiometer 5 kOhm, add-on	P5000A
	Feedback potentiometer 5 kOhm, add-on, grey	P5000A GR
	Feedback potentiometer 10 kOhm, add-on	P10000A
	Feedback potentiometer 10 kOhm, add-on, grey	P10000A GR
	Connecting cable 5 m, A+B: RJ12 6/6, To ZTH/ZIP-USB-MP	ZK1-GEN
	Connection cable 5 m, A: RJ11 6/4, B: Free wire end, To ZTH/ZIP-USB-MP	ZK2-GEN
	Mechanical accessories	Actuator arm, for standard spindle clamp (reversible) K-SA
Actuator arm, for one-sided spindle clamp K-ENSA		AH-25
Shaft extension 250 mm, for damper spindles Ø 8...25 mm		AV8-25
Spindle clamp, one side for NM..A		K-ENMA
Spindle clamp, one side for NM..A, SM..A		K-ENSA
Straight ball joint with M8, suitable for damper crank arms KH8		KG10A
Angled ball joint with M8, suitable for damper crank arms KH8		KG8
Damper crank arm, for damper spindles		KH8
Spindle clamp, reversible for NM..A and LMQ..		K-NA
Angle of rotation limiter, for K-NA		20334-00001
Universal mounting bracket 180 mm		Z-ARS180
Form fit insert 8x8 mm, for NM..A		ZF8-NMA
Form fit insert 10x10 mm, for NM..A / SM..A		ZF10-NSA
Form fit insert 12x12 mm, for NM..A / SM..A		ZF12-NSA
Form fit insert 15x15 mm		ZF15-NSA
Form fit insert 16x16 mm, for NM..A / SM..A		ZF16-NSA
Mounting kit for linkage operation, NM..A for flat installation		ZG-NMA
Base plate extension from NM..A to NM..		Z-NMA
Position indication for LM..A, NM..A, SM..A, GM..A		Z-PI

Accessories

Service Tools	Description	Type
	Service Tool, for MF/MP/Modbus/LonWorks actuators and VAV-Controller	ZTH EU
	Belimo PC-Tool, software for adjustments and diagnostics	MFT-P
	Adapter to Service-Tool ZTH	MFT-C

Electrical installation



Notes

- Connection via safety isolating transformer.
- The wiring of Modbus RTU (RS485) is to be carried out in accordance with applicable regulations (www.modbus.org). The device has switchable resistors for bus termination.
- Modbus-GND: Supply and communication are not galvanically isolated. Connect earth signal for devices with one another.

Wiring diagrams

Modbus wiring

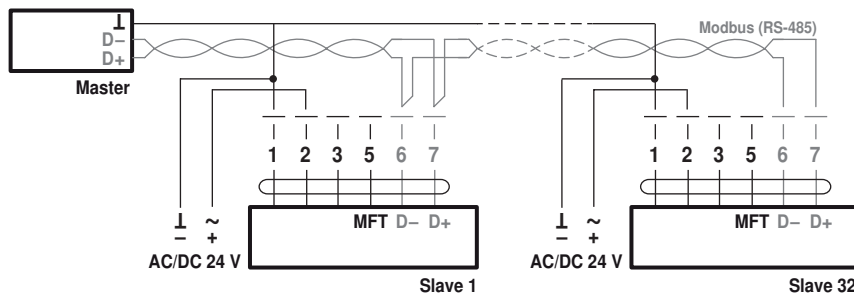

Connection without sensor

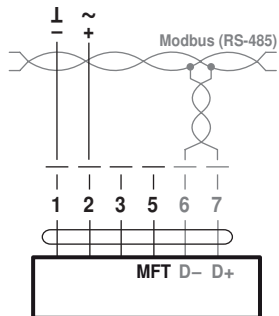

Note

Modbus signal assignment:
C₁ = D- = A
C₂ = D+ = B

Connection with passive sensor, e.g. Pt1000, Ni1000, NTC

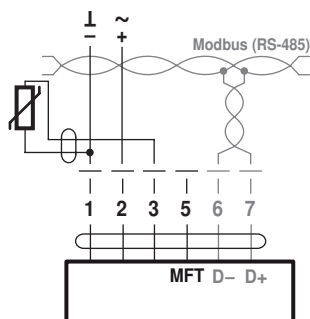

Ni1000	-28...+98 °C	850...1600 Ω ²⁾
PT1000	-35...+155 °C	850...1600 Ω ²⁾
NTC	-10...+160 °C ¹⁾	200 Ω...60 kΩ ²⁾

1) depending on type
2) Resolution 1 Ohm

Electrical installation

Connection with switching contact, e.g. pressure control device

Connection with active sensor, e.g. 0...10 V @ 0...50°C

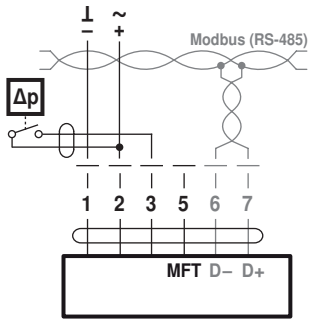

Requirements for switching contact:
The switching contact must be able to accurately switch a current of 16 mA @ 24 V.

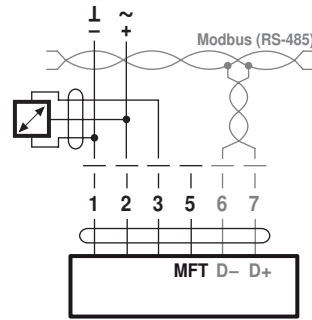

Possible voltage range:
0...32 V (resolution 30 mV)

Modbus communication parameters

Register

	No.	Adr	Register
In operation	1	0	Setpoint [%]
	2	1	Override control
	3	2	Command
	4	3	Actuator type
	5	4	Relative position [%]
	6	5	Absolute position [°] [mm]
	7	6	Relative volumetric flow [%] (only for VAV/EPIV)
	8	7	Absolute volumetric flow (pressure) [m ³ /h] [l/min] [Pa] (only for VAV/EPIV)
	9	8	Sensor value [mV] [Ω] [-]
Service	101	100	Series number 1st part
	102	101	Series number 2nd part
	103	102	Series number 4th part
	104	103	Firmware version (Modbus module)
	105	104	Malfunction and service information
	106	105	Min [%]
	107	106	Max [%]
	108	107	Sensor type
	109	108	Bus fail position

- Registers in Bold can be written
- Registers <100 (In operation) which can be written are volatile and should therefore be updated periodically
- Registers >100 which can be written are non-volatile

Commands

All data is arranged in a table and addressed by 1..n (register) or 0..n-1 (address). No distinction is made between data types (Discrete Inputs, Coils, Input Registers, Holding Registers). As a consequence, all data can be accessed with the two commands for Holding Register. The commands for Discrete Inputs and Input Registers can be used as an alternative.

Standard commands:

Read Holding Registers [3]

Write Single Register [6]

Optional commands:

Read Discrete Inputs [2]

Read Input Registers [4]

Write Multiple Registers [16]

Note regarding Read Discrete Inputs

The command reads one or more bits and can alternatively be used for register 105 (Malfunction and service information). The start address to be used is 1664.

Modbus communication parameters

Register 1: Setpoint Setpoint for actuator setting or volumetric flow in hundredths of one percent, i.e. 0...10 000 corresponds to 0...100%

Register 2: Override control Overriding the setpoint with defined values

Override control	
0	None
1	Open
2	Close
3	Min
5	Max

Register 3: Command Initiation of actuator functions for service and test; the register is reset automatically.

Command	
0	None
1	Adaption
2	Test run
3	Synchronisation
4	Reset actuator malfunctions

Register 4: Actuator type Actuator type; the allocation may deviate from the basic category with some actuators.

Actuator type	
0	Actuator not connected / not known
1	Air/water actuators with/without safety function
2	Volumetric flow controller VAV / EPIV
3	Fire damper actuator

Register 5: Relative position Relative position in hundredths of one percent, i.e. 0 ... 10 000 correspond to 0 ... 100%

Register 6: Absolute position Absolute position
0 ... 10 000 (65535 if not supported by the actuator)
The unit depends on the device:
[°] for actuators with rotary movement
[mm] for actuators with linear movement

Register 7: Relative volumetric flow Relative volumetric flow in hundredths of one percent of Vnom, i.e. 0 ... 10 000 correspond to 0 ... 100%.
This value is available only for VAV controllers and EPIV devices (actuator type: 2).
For all other types, 65535 will be entered.

Register 8: Absolute volumetric flow Absolute volumetric flow
This value is available only for VAV controllers and EPIV devices (actuator type: 2).
For all other types, 65535 will be entered.
The unit depends on the device:
[m³/h] for VAV controllers (or [Pa] for pressure applications)
[l/min] for EPIV devices

Register 9: Sensor value Current sensor value; dependent on the setting in Register 108
The unit depends on the sensor type: [mV][Ω] [-]

Register 101 - 103: Series number Each device has an unambiguous series number which is either impressed on or glued to the housing. The series number consists of 4 segments, although only parts 1, 2 and 4 are displayed on Modbus.
Example: 00839-31324-064-008

Register 101	Register 102	Register 103
1st part	2nd part	4th part
00839	31234	008

Register 104: Firmware Version Firmware version of Modbus module (VX.XX)
e.g. 101 V1.01

Modbus communication parameters

Register 105: Malfunction and service information

The status information is split into messages about the actuator (malfunctions) and other service information.

	Bit	Description
Malfunctions (low byte)	0	Excessive utilisation
	1	Mechanical travel increased
	2	Mechanical overload
	3	–
	4	Safety-relevant faults (fire protection only)
	5	Damper test error (fire protection only)
	6	Duct temperature too high (fire protection only)
	7	Smoke detector tripped (fire protection only)
Service (high byte)	8	Internal activity (test run, adaption, ...)
	9	Gear disengagement active
	10	Bus watchdog triggered
	11	–
	12	–
	13	–
	14	–
	15	–

The malfunction bits can be reset with Register 3 (command 4) or with the Belimo PC-Tool. Malfunctions 0 and 4 cannot be reset.

Register 106: Min / Vmin setting

Minimum limit (position or volumetric flow) in hundredths of one percent, i.e. 0...10 000 correspond to 0...100%
Caution: Changing the setting may result in malfunctions.

Register 107: Max / Vmax setting

Maximum limit (position or volumetric flow) in hundredths of one percent, i.e. 2000...10 000 correspond to 20...100%
Caution: Changing the setting may result in malfunctions.

Register 108: Sensor type

Sensor type connected to the actuator; in the absence of sensor specification, the switching at the Y input will have the effect of a local compulsion.

Notes
 – After changing the sensor type, the actuator must always be restarted in order for correct sensor values to be read out.
 – By using actuator variants with RJ12 sockets (J6) sensor values are not available, as connecting a sensor is not possible.

Sensor type	
0	None
1	Active sensor (mV)
2	Passive sensor 1 k (Ω)
3	Passive sensor 1 ... 20 k (Ω)
4	Switching contact (0 / 1)

Register 109: Bus fail position

Modbus communication is not monitored as standard. In the event of a breakdown in communication, the actuator retains the current setpoint. The bus monitoring controls the Modbus communication. If neither the setpoint (Register 1) nor the override control (Register 2) is renewed within 120 seconds, the actuator controls to the bus fail position. Triggered bus monitoring is indicated in Register 105.

Bus fail position	
0	Last setpoint (no bus monitoring)
1	Fast close if time is exceeded
2	Fast open if time is exceeded
3	Parameterized intermediate position Mid if time is exceeded

Operating controls and indicators

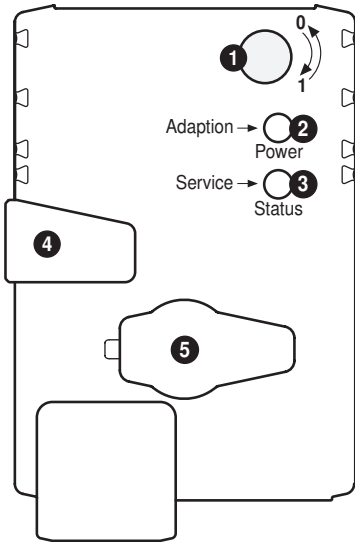

1 Direction of rotation switch

Switch over: Direction of rotation changes

2 Push-button and LED display green

Off: No power supply or malfunction
 On: In operation
 Flashing: In address mode: Pulses according to set address (1...16)
 When starting: Reset to factory setting (Communication)
 Press button: In standard mode: Triggers angle of rotation adaptation
 In address mode: Confirmation of set address (1...16)

3 Push-button and LED display yellow

Off: Standard mode
 On: Adaptation or synchronising process active
 or actuator in address mode (LED display green flashing)
 Flickering: Modbus communication active
 Press button: In operation (>3 s): Switch address mode on and off
 In address mode: Address setting by pressing several times
 When starting (>5 s): Reset to factory setting (Communication)

4 Gear disengagement button

Press button: Gear disengages, motor stops, manual override possible
 Release button: Gear engages, synchronisation starts, followed by standard mode

5 Service plug

For connecting parameterisation and service tools

Check power supply connection

2 Off and **3** On Possible wiring error in power supply

Service



Notes

- The actuator can be parameterised by PC-Tool and ZTH EU via the service socket.

Quick addressing Modbus

1. Press the "Service" button until the green "Power" LED is no longer illuminated. The green "Adaption" LED flashes in accordance with the previously set address.
 2. Set the address by pressing the "Service" button the corresponding number of times (1-16).
 3. The green LED flashes in accordance with address that has been entered (1-16). If the address is not correct, then this can be reset in accordance with Step 2.
 4. Confirm the address setting by pressing the green "Adaption" button. If no confirmation occurs for 60 seconds, then the address procedure is ended. Any address change that has been made will be discarded.
- The resulting Modbus address is made up of the set basic address plus the short address (e.g. 140+7=147).

Service tools connection

ZTH EU connection

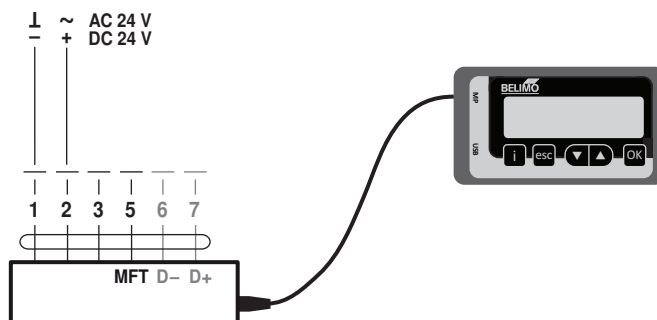

Service

PC-Tool connection

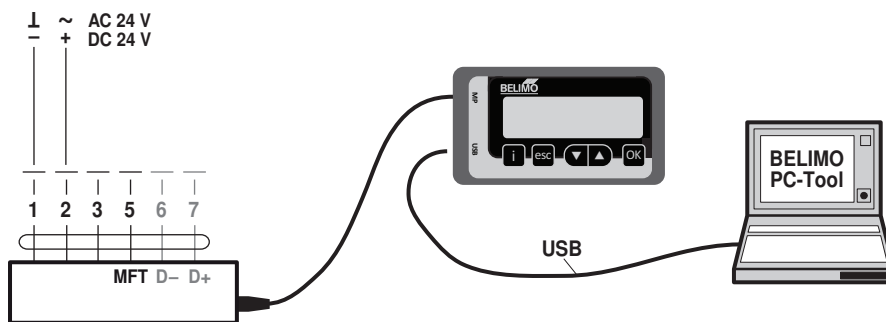

Dimensions [mm]

Spindle length

	Min. 40
	Min. 20

Clamping range

	8...26.7	≥8	≤26.7
	8...20	≥8	≤20

*Option: Spindle clamp mounted below
(accessories K-NA needed)

Dimensional drawings

